



Diesel Care & Performance Inc  
"Care is at the center of everything we do"

## Fuel Injection Pump Replacement

### REMOVAL

1. Disconnect negative battery terminal.
2. Remove throttle linkage.

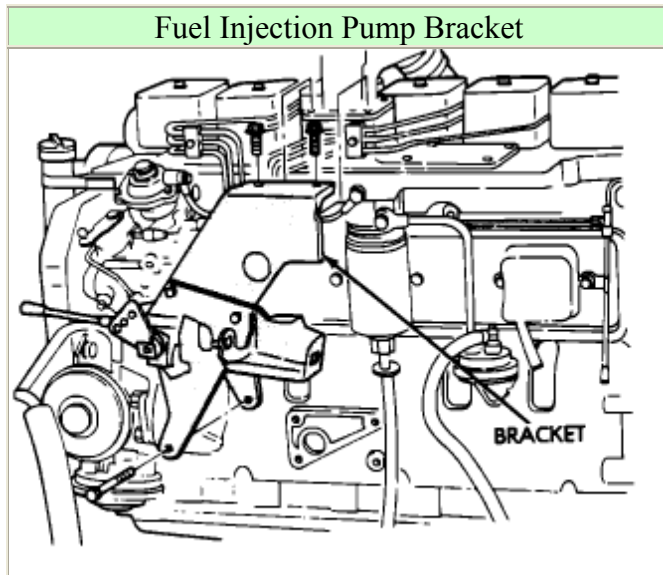

3. Remove injection pump bracket.

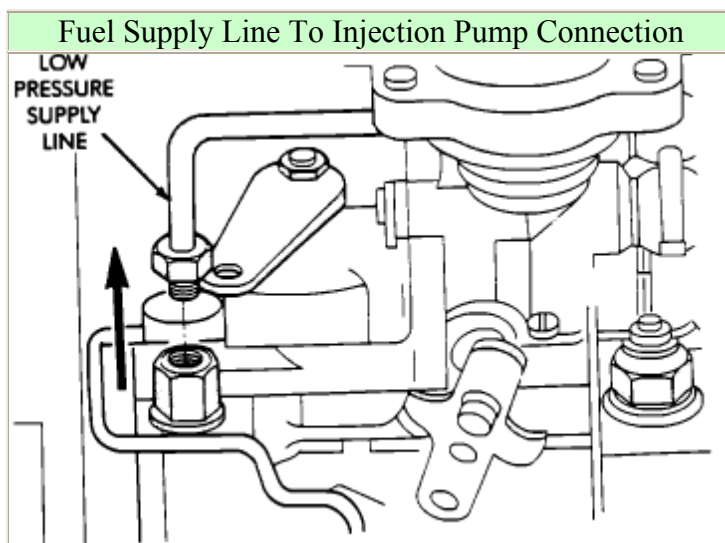



Diesel Care & Performance Inc  
“Care is at the center of everything we do”

4. Remove injection pump supply line from the injection pump.
5. Remove the high pressure supply lines that go to the injectors
6. Disconnect the solenoid electrical connector from the fuel solenoid.

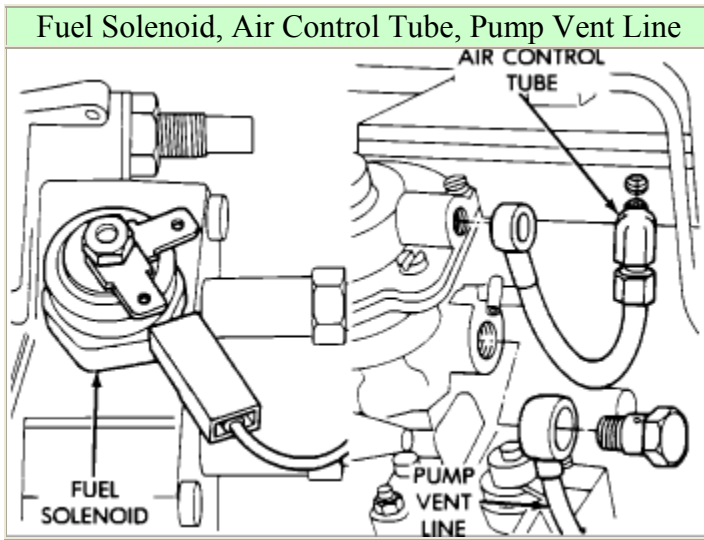

7. Remove the air control tube.
8. Remove the injection pump vent line and cap screw.

**CAUTION:** The control lever is indexed to the control lever shaft during calibration. Do not remove the control lever from the injection pump.

Injection Pump Support Bracket



Diesel Care & Performance Inc  
“Care is at the center of everything we do”

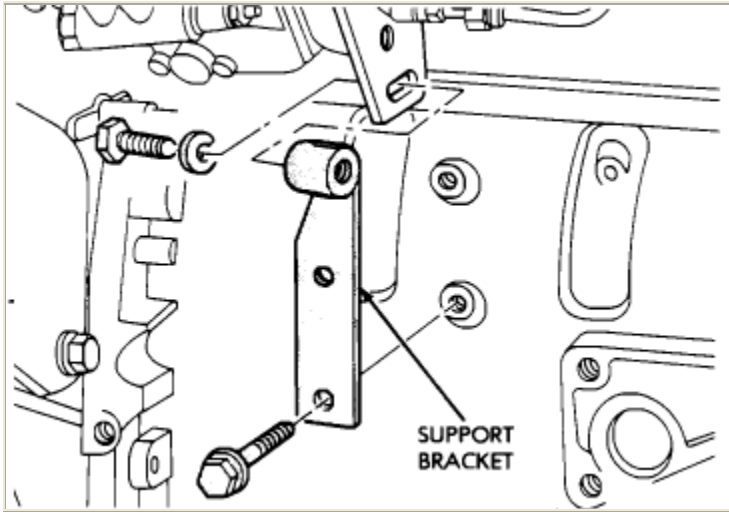

9. Remove the injection pump support bracket.

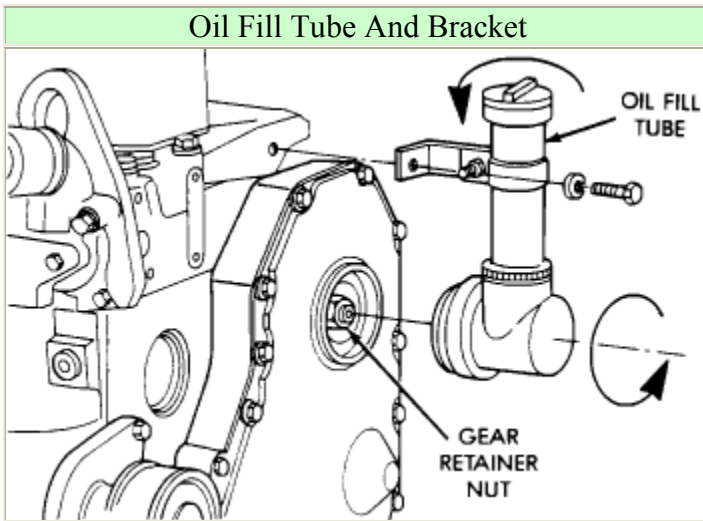

10. Remove the oil filler tube bracket mounting screw and the oil filler tube and adapter from the engine front cover.

**CAUTION:** If the gear retainer nut or washer falls into the gear housing, the gear cover has to be removed to retrieve them before starting the engine.

11. Place a shop towel below the retainer nut in the gear housing cover opening to prevent the nut or washer from falling into the housing. Remove the gear retaining nut and washer.



Diesel Care & Performance Inc  
"Care is at the center of everything we do"

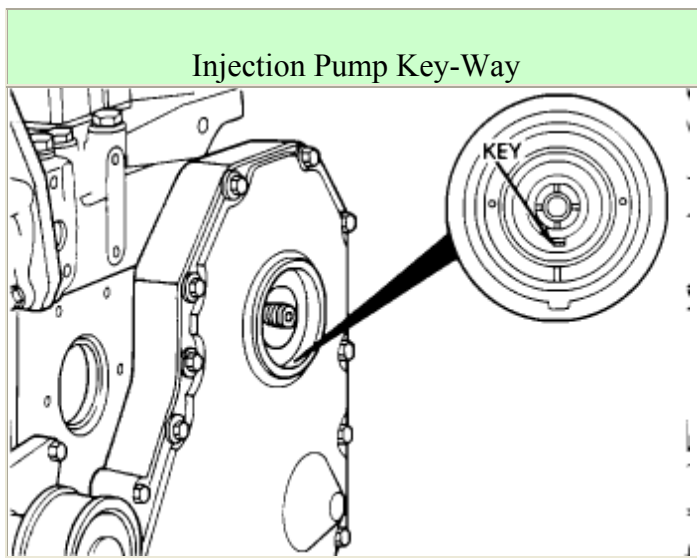
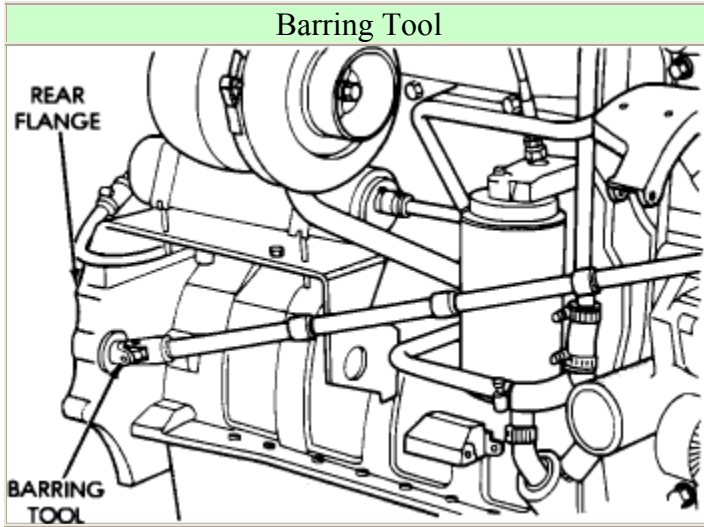

12. Rotate the engine with the barring tool until the injection pump key-way is pointing directly down.

Timing Pin - Cylinder #1



Diesel Care & Performance Inc  
“Care is at the center of everything we do”

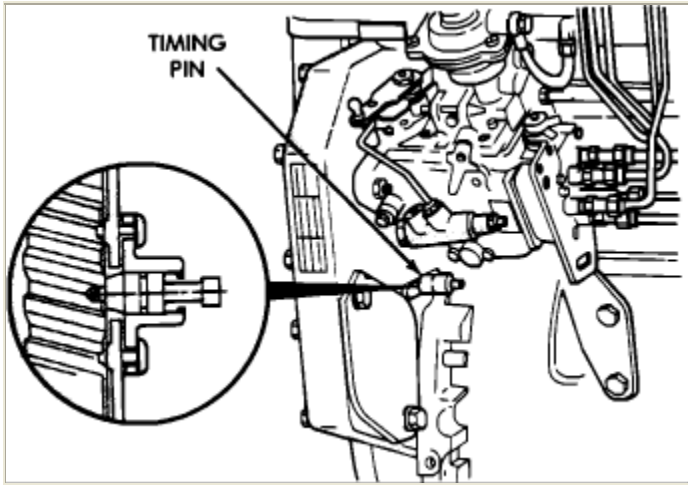

13. Slowly rotate the engine, with the barring tool, while pushing in on the timing pin. The pin will fall into a hole in the cam gear when the engine reaches Top Dead Center (TDC) of #1 cylinder. Stop rotating the engine once the timing pin drops into the cam gear.
14. Pull the timing pin out of the camshaft gear.

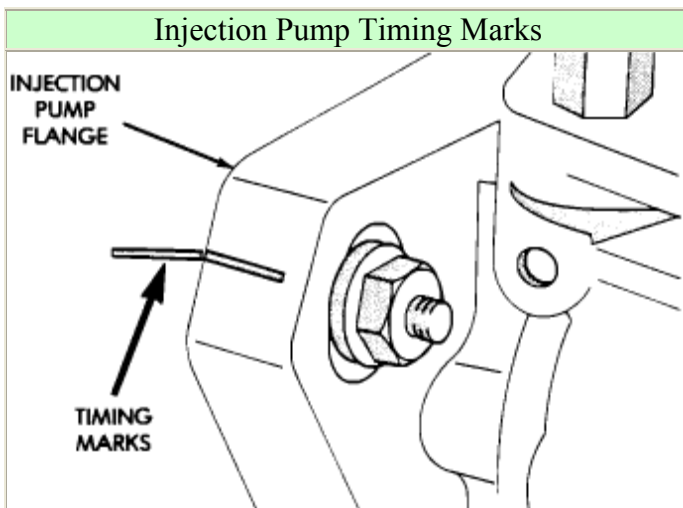

**NOTE:** Visually inspect the timing marks on the flange of the injection pump. Each pump and engine have unique timing marks. It is not possible to exchange pumps and use the same timing marks for alignment.

**NOTE:** All injection pumps have a lock-screw. The lock-screw is used to lock the



Diesel Care & Performance Inc  
"Care is at the center of everything we do"

injection pump shaft in place once TDC has been located. Rebuilt and new injection pumps should come with the shaft locked in place with the lock-screw.

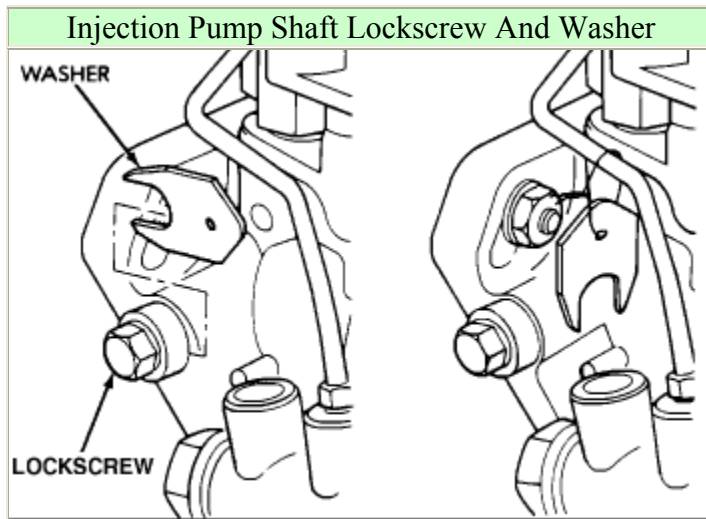

15. Loosen the injection pump lock-screw. Remove the lock-screw washer and attach it to the injection pump flange with a piece of wire for use during installation.
16. Tighten the lock-screw

**CAUTION:** Make sure the injection pump key doesn't fall into the gear housing, because the gear cover would have to be removed to retrieve it before starting the engine.

#### Pulling Pump Gear Off Of Shaft



Diesel Care & Performance Inc  
"Care is at the center of everything we do"

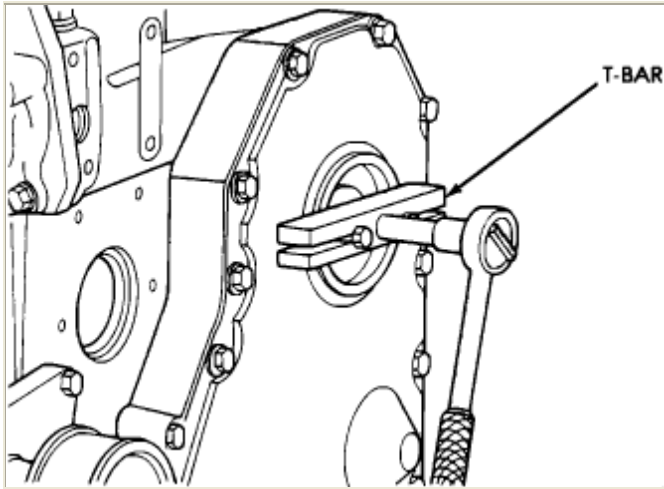

17. Use a T-bar to pull the injection pump gear off the pump shaft. Use 8mm X 1.25mm screws to attach the T-bar to the shaft.
18. Remove the injection pump mounting nuts.
19. Remove the injection pump and clean the gasket surfaces on the engine block and the injection pump.

## INSTALLATION

**NOTE:** Make sure that cylinder #1 is positioned at top dead center of compression stroke before installing the injection pump.

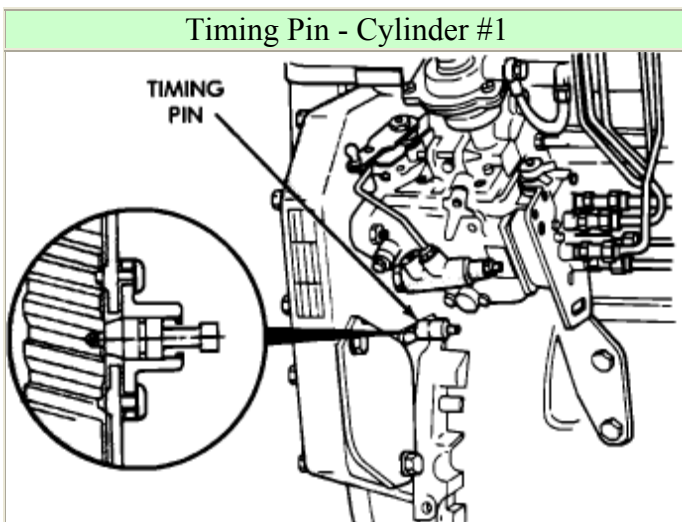



Diesel Care & Performance Inc  
“Care is at the center of everything we do”

1. Slowly rotate the engine, with the barring tool, while pushing in on the timing pin. The pin will fall into a hole in the cam gear when the engine reaches Top Dead Center (TDC) of the compression stroke of #1 cylinder. Stop rotating the engine once the timing pin drops into the cam gear.
2. Pull the timing pin out of the camshaft gear.
3. Install a new injection pump gasket.

**NOTE:** The shaft of the new injection pump should be locked into place so that its key-way is positioned to align with the drive gear slot when the engine is at TDC of compression stroke of #1 cylinder.

**CAUTION:** Make sure the injection pump key doesn't fall into the gear housing, because the gear cover would have to be removed to retrieve it before starting the engine.

4. Install the injection pump and tighten the mounting nuts finger tight. Make sure that the injection pump can slide in the mounting slots.

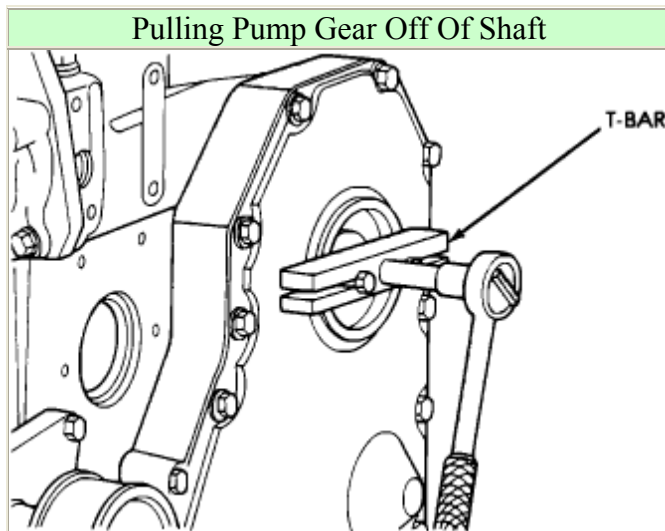

5. Remove the T-bar from the injection pump drive gear.
6. Install the injection pump drive shaft spring washer and retaining nut, and torque the retaining nut to 11 to 15 lb-ft (15 to 20 Nm). **CAUTION:** Do not overtighten. This is not the final torque for the retaining nut.
7. If installing a new or rebuilt injection pump without a timing mark, take up gear lash by rotating the pump housing counterclockwise towards the cylinder head. If



Diesel Care & Performance Inc  
"Care is at the center of everything we do"

- installing original injection pump, rotate the injection pump housing until the timing marks align.
8. Torque the mounting nuts to 18 lb-ft (24 Nm).

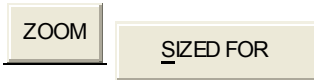
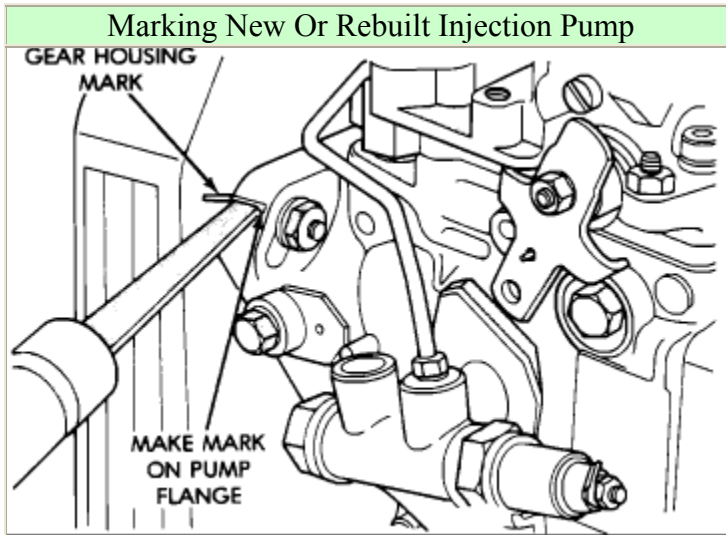

9. If a rebuilt or new injection pump was installed, mark the injection pump flange in line with the mark on the gear housing.

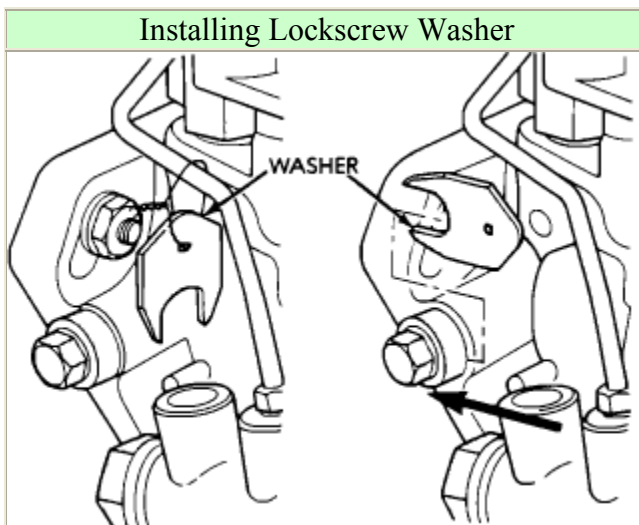



Diesel Care & Performance Inc  
“Care is at the center of everything we do”

10. Loosen the injection pump lockscrew and install the washer that was wire tagged to the injection pump. Torque the lockscrew to 10 lb-ft (13 Nm).
11. Install the injection pump support bracket and tighten the bolts finger tight. Torque the bolts to 18 lb-ft (24 Nm) using the following sequence:
  - Tighten support bracket to engine block bolts.
  - Tighten support bracket to injection pump bolts.
  - Tighten throttle support bracket mounting bolts.
12. Torque injection pump drive gear retaining nut to 48 lb-ft (65 Nm).

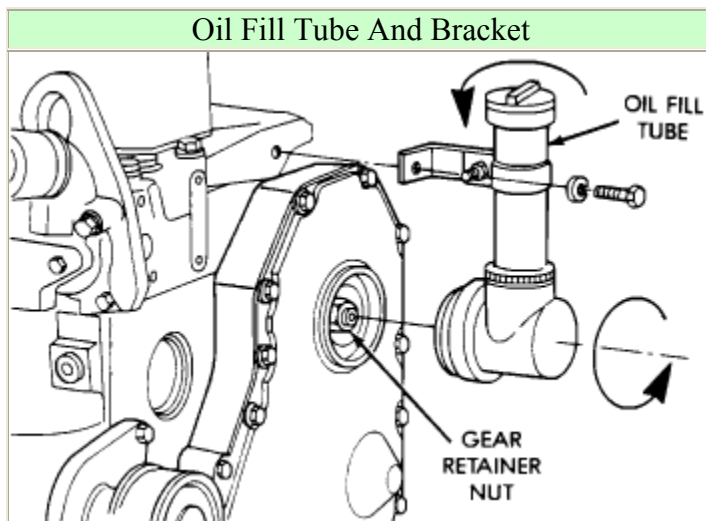

ZOOM

SIZED FOR

13. Install oil filler assembly to gear housing. Torque clamp screw to 32 lb-ft (43 Nm).
14. Time the injection pump. [See: Adjustments\Fuel Injection Pump Timing](#) Install high pressure supply lines. [See: Fuel Supply Line\Service and Repair\High Pressure Lines - Replacement](#)

#### Fuel Supply Line To Injection Pump Connection



Diesel Care & Performance Inc  
"Care is at the center of everything we do"

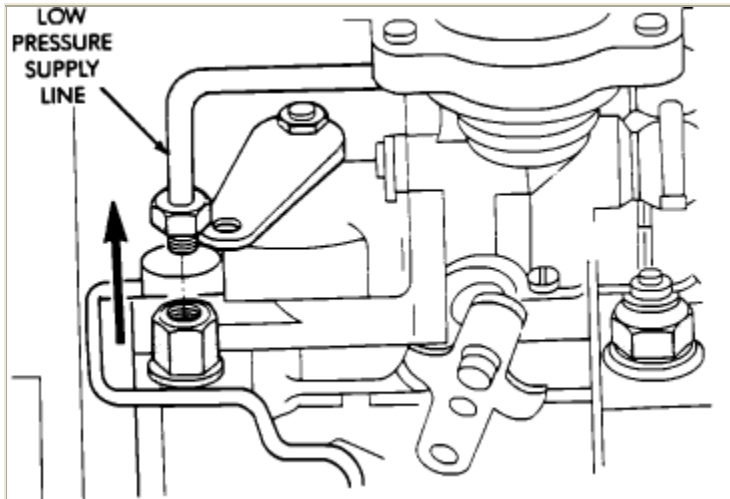

15. Install injection pump supply line. Torque supply line connections to 24 lb-ft (24 Nm).
16. Connect solenoid electrical connector to fuel solenoid.
17. Install fuel pump vent line and capscrew.
18. Install air fuel control tube.

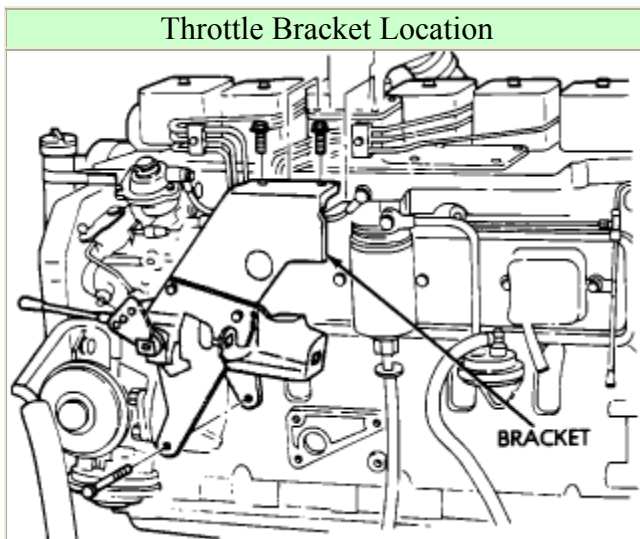



Diesel Care & Performance Inc

*“Care is at the center of everything we do”*

19. Install throttle bracket and torque mounting bolts to 18 lb-ft (24 Nm).
20. Install throttle linkage. When connecting the cable to the control lever, adjust the length so the lever has stop-to-stop movement. Adjust if necessary.
21. Bleed fuel system.
22. Adjust low idle speed if necessary.
23. Inspect throttle linkage to ensure that the control lever breaks over the full throttle position. Adjust if necessary.
24. Connect negative battery terminal to battery.